

UNIFIRE 26C

Portable plasma cutting system for manual cutting with built-in compressor



- UNIFIRE 26C is a single phase 25A portable plasmasystem with built in compressor that can cut up to 8mm thickness.
- UNIFIRE 26C is with its built in compressor the given choice when you have the need for a completely portable system.
- Just connect power! UNIFIRE 26C is easy to carry, setup and to use.
- Perfect for all mobile cutting applications such as steel construction at construction sites, ventilation ducts, service & maintenance, etc.

Technical data:

Power supply	230V, 1~ 50/60Hz
Fuse	16A@230V, slow blow
Maximum power	2.85 kVA*
Process power	95V, 5-25A
Duty cycle	25%@25A
Power factor	0,95
Open circuit voltage	424 VDC
Protection class	IP 23S
Cooling	F
Temperature class	F
Dimensions LxWxH	390x225x360
Weight	13 kg
Max cutting capacity	8 mm
Quality cut	6 mm
Pressure/flow	Built-in compressor

* when connected to a generator power supply the recommended minimum power of the generator is 1.5 times the maximum power of the plasma system.

Delivery scope:

- Power source
- Torch PTA 25 4m
- Consumable kit
- Mains supply cable
- Work lead cable 3m
- Shoulder strap
- Users manual

Consumables and accesories PTA 25

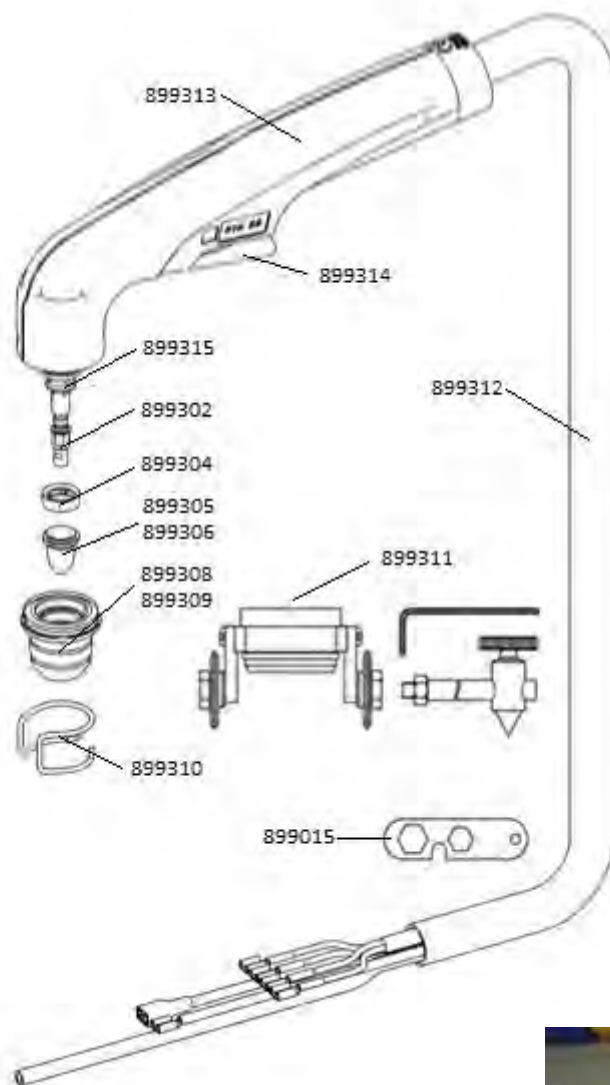

Part No.	Denomination
454057	UNIFIRE 26C with 4 m PTA 25
899315	Torch body PTA 25
899302	Electrode
899304	Swirl ring
899305	Nozzle 0.65 5-20A
899306	Nozzle 0.8 15-30A
899308	Protective cap UF 26C
899309	Protective cap UF 31 PFC
899310	Distance cutting guide
899311	Circle cutting guide PTA 25
899313	Handle PTA 25
899314	Button PTA 25
899312	Hose parcel PTA 25 4m
899015	Consumable tool
899301	Torch PTA 25 4m complete



SPT Plasmateknik AB

STATE OF THE ARC PLASMA CUTTING TECHNOLOGY

SPT Plasmateknik AB was founded in 1987 by engineers in the field of plasma cutting. The company is located in Lund, about 45 minutes from Copenhagen Airport.

With over 25 years experience in plasma cutting, we have a solid knowledge of how to make the best use of plasma cutting and gouging. With a wide product range SPT can offer systems for manual, mechanized and robotic plasma cutting that meet the needs of every application.

For more information, contact us by phone +46-46-184800 or send an email to info@spt.se. On our website www.spt.se you will find more information about our products and where you can find our distributors.

